



Company guide
Toyo Shinkou Co.,Ltd

TOYO SHINKOU

【 Company Profile 】

- Established: December 24, 1971
- Head office location: 1396 Kitaema, Izunokuni City, Shizuoka Prefecture
- Capital: 60 million yen
- Shareholder: Toray Advanced Film Co., Ltd. (100%)
- Number of employees: 141
- Office: Head Office/Nagaoka Factory (Shizuoka (Izunokuni City))
Offices (Fukushima, Takatsuki, Nakatsugawa)

【Office list】

Head Office/Nagaoka Factory 1396 Kitaema, Izunokuni City, Shizuoka Prefecture TEL055-948-4655

Fukushima Office: 380-8 Suwa-cho, Kagamiishi-cho, Iwase-gun, Fukushima Prefecture Inside Toray Advanced Film Co., Ltd. Fukushima Factory

Takatsuki Office: 1-5 Sakuramachi, Takatsuki City, Osaka Prefecture Inside the Takatsuki Plant of Toray Advanced Film Co., Ltd.

Nakatsugawa Office 1683-1883 Nasugawa, Nakatsugawa City, Gifu Prefecture Inside the Nakatsugawa Factory of Toray Advanced Film Co., Ltd.



Nakatsugawa Office



Takatsuki Office



Fukushima Office

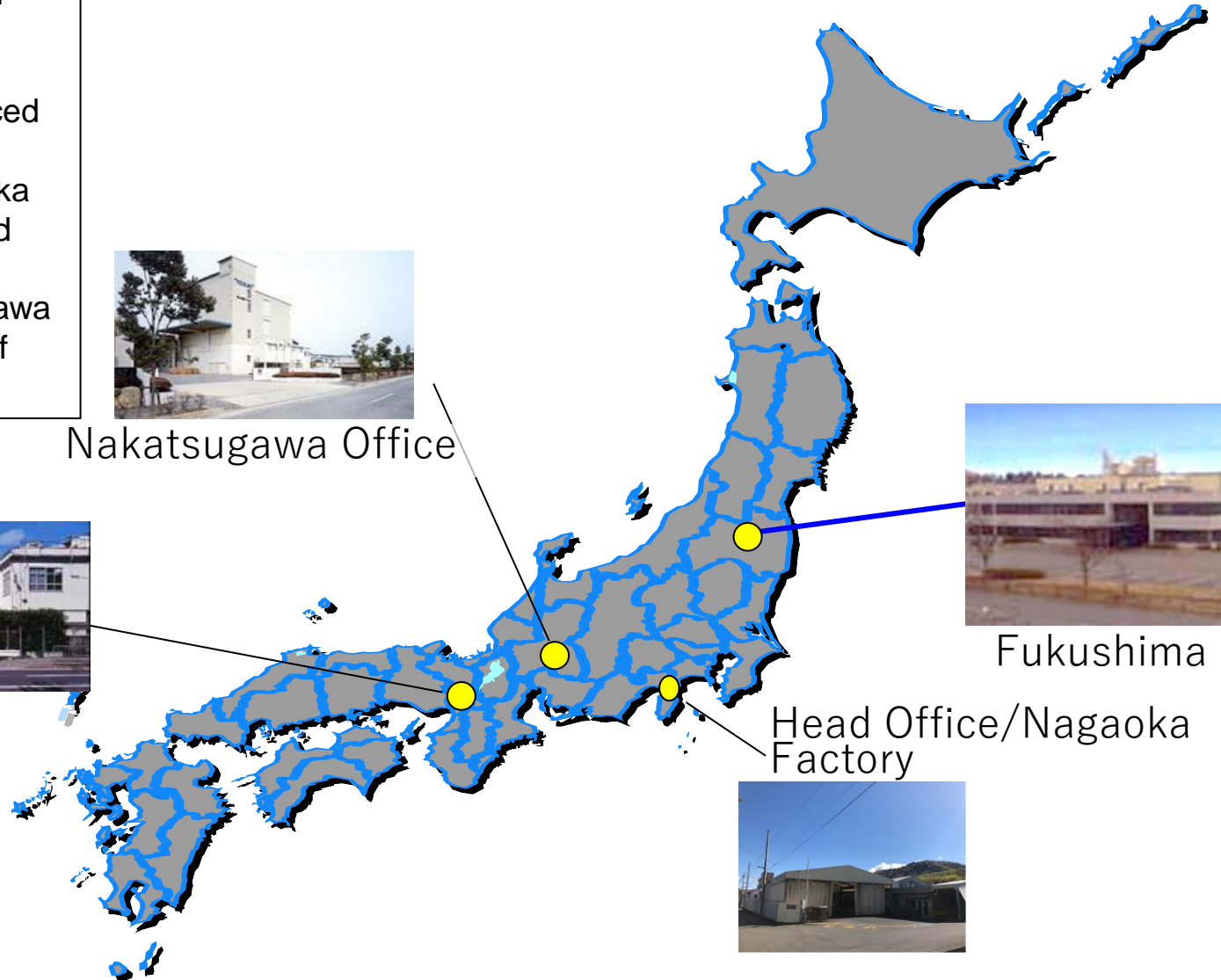

Head Office/Nagaoka Factory



- ◆ Of processed film products manufactured by Toray Advanced Film Co., Ltd. Contracting slitting, inspection, packaging, packaging, logistics operations, and development assistance.
- ◆ Film processing (Nagaoka Factory) (Coating, slitting, hairline, paster, corona treatment, etc.)
- ◆ Toray Advanced Film Co., Ltd. Contracting for maintenance management work.
- ◆ Sales of waste plastics, paper tubes, and recycled products. Sales of molded products such as transportation hanging plastic, roll pads, and side plates

【 Overview of the Nagaoka Factory 】

- ◆ Coating processing · Silicone coating
 - Colored coat, easy adhesion coat, etc.
- ◆ Slit processing · General-purpose slit (~1300mm)
 - Narrow width micro slit (4 mm width ~)
 - Slit for transfer foil (12mm width~)
 - Processing of small rolls of transfer foil
(640mm x 120~240m rolled products)
- ◆ Hairline processing · Hairline processing for each film material (PET, PP, PMMA, PC, etc.)
- ◆ Pasta processing · Etching processing of aluminum vapor deposition
- ◆ Corona treatment · Corona discharge treatment for plastic film, paper, etc.

-
- Main equipment
- Gravure coater [MAX 1350mm width]
 - Hairline processing equipment [MAX 1350mm width]
 - General-purpose slitter [MAX 1350mm width]
 - Micro slitter [MAX 660mm width]
 - Rewinding machine for small rolls of transfer foil [MAX 640mm width]
Winding: 1 inch
 - Micro slitter for transfer foil [MAX 700mm width] Winding: 1 inch, 3 inch
 - Pasta processing machine [MAX 1200mm width]
 - Corona treatment [MAX 1350mm width]

Silicone coated film and non-silicone film

- Silicone-coated film is a PET film coated with a release imparting agent such as silicone resin. Can be used for a wide range of purposes, including coating, electronic parts, labels, and poultices.
- We also offer a “non-silicone type” that can be used for applications where silicone migration is not desired.
- Main uses: Manufacturing process paper for adhesives, manufacturing process paper (ceramic sheets), pharmaceutical dispersing agents, etc.

Type	Silicone type					Non-Silicone type			
	Light peeling			Medium peeling		Light peeling	Medium peeling		Heavy peeling
	TS-1	TS-2	TS-3	TS-4DL3	TS-4	TSN-4W	NK	WK2	P
Peeling Force (N/50mm)	0.1	0.1	0.09	0.2	1.2	0.3	0.9	0.9	8
Features	<ul style="list-style-type: none"> • General-purpose product, • Solvent resistance, • Abrasion resistance 			<ul style="list-style-type: none"> • Stable peeling force • Lightly adhesive tape 		<ul style="list-style-type: none"> • Dislikes silicone transfer Non-silicone type 			
Usage example	<ul style="list-style-type: none"> • For ceramic capacitors • For green sheet processes • Adhesive tape • Double-sided tape • Adhesive sheet • For manufacturing processes 			<ul style="list-style-type: none"> • For ceramic capacitors • Adhesive sheets • For manufacturing processes 		<ul style="list-style-type: none"> • For ceramic controllers • For green sheet process • For manufacturing process 		<ul style="list-style-type: none"> • For process, marking, film, etc. 	

Peel strength of silicone-coated and non-silicone films

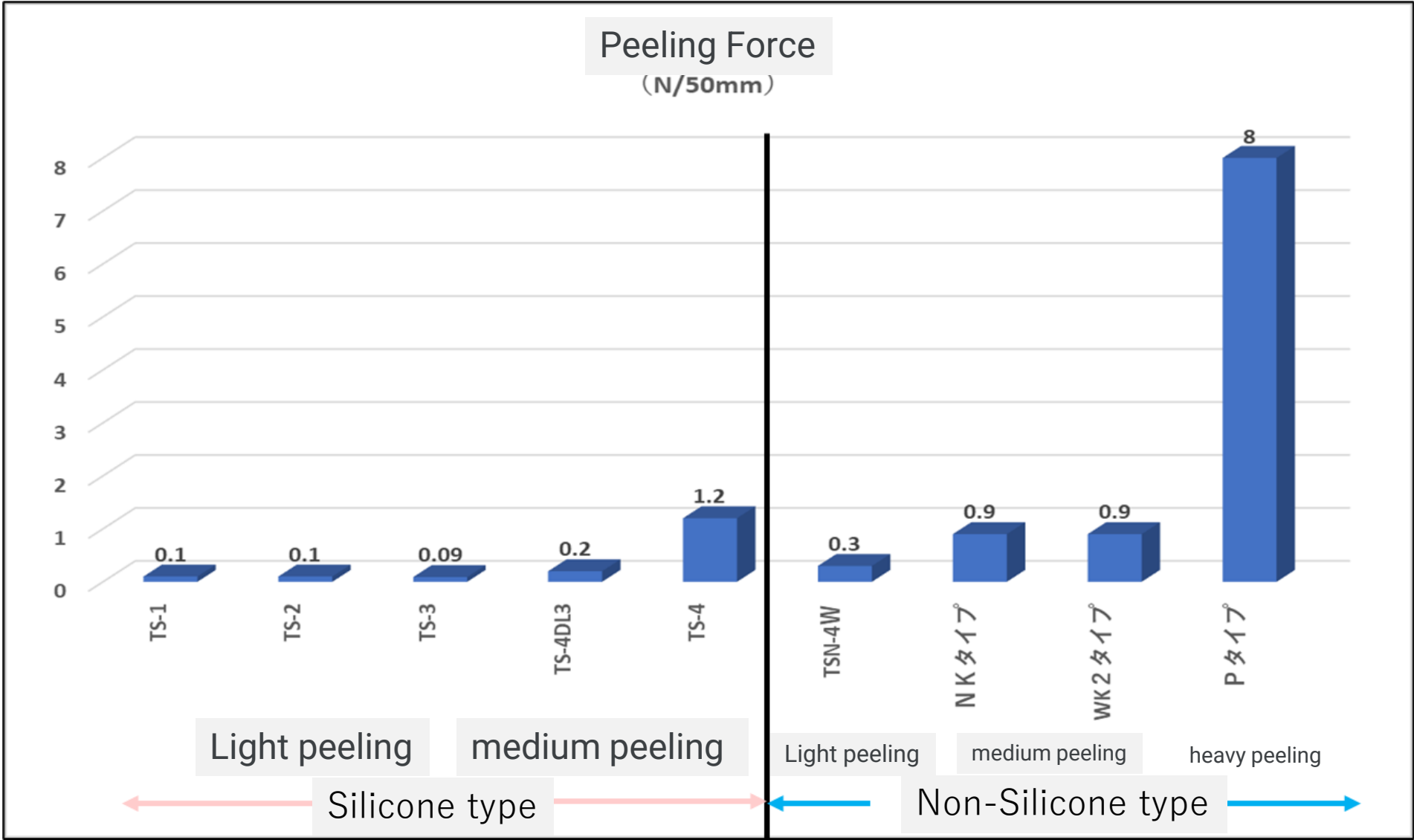

【 Easy adhesion coated film 】

We have a product group with easy adhesion that meets the needs of PET films, etc.

- For offset ink and flexographic ink (oxidative polymerization, UV curing type)
Excellent adhesiveness and adhesion to thermal transfer ribbons. It can also be used as media for laser printers.
- Can be used for a variety of purposes, from labels to miscellaneous goods.

Product name	Product features
T-coat	Standard product. Compatible with oxidation polymerization ink. Excellent adhesion for thermal transfer.
TP coat	thick coating type. Adhesion of UV ink is improved compared to T coat.
K Coat	Excellent adhesive strength for both UV ink and thermal transfer.

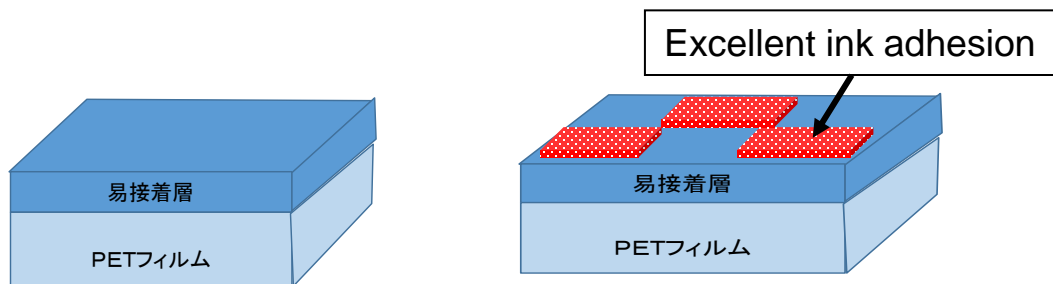

composition

Offset printing, silk printing, etc.



Examples of printed products

Easy-to-adhere coated products "Examples of use"

- For trading cards and packaging, it can be coated on the PET surface for easy adhesion and gives ink adhesion and AS properties.
- Excellent adhesion to offset ink.
- General composition for cards: Printing layer (UV, etc.)/easy adhesion layer/PET (#12 and above)/AL vapor deposition/adhesive layer/paper
- Original roll size (for cards): 930mm, 790mm, 630mm x 3000~6000m • Characteristics: transparency, slipperiness, ink adhesion, AS properties (slipperiness)

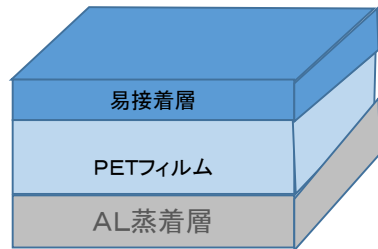

Easy-adhesive coating composition (trading cards)

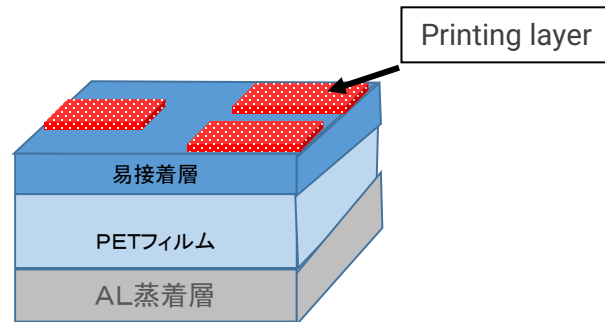

Offset printing



Trading Cards

Hard Coat Film

- Hard-coated onto untreated PET surface, it adheres well to PET and has excellent surface hardness and chemical resistance.
- Resistant to stains, water-based and oil-based markers can be wiped off.
- Excellent chemical resistance (alcohol resistance, bleach resistance).

【 Hard Coat Physical Properties Table 】

Test items	Evaluation method	result
• Pencil hardness	Pencil Hardness Test	2 H
• Alcohol resistance	50% ethyl alcohol drip: 1 hour later, no significant changes	O K
• Resistant to kitchen bleach	Kitchen bleach dripping: 1 hour later No significant changes	O K
• Water-based Magic Contamination	Erasability after writing dries	Erasability O K
• Oil-based marker stains	Erasability after writing dries	Erasability O K

【 Hairline processing】

- Hairline processing is a fine line processing like hair on the surface of the film,
By vapor-depositing metal, it is possible to obtain a metal-like decoration of stainless steel or aluminum.
- Main applications
- Home appliance applications: transfer foils, adhesive labels
- Automotive applications: Insert molding decoration
- Packaging applications: Transferring onto paper or laminating

Application example of hairline

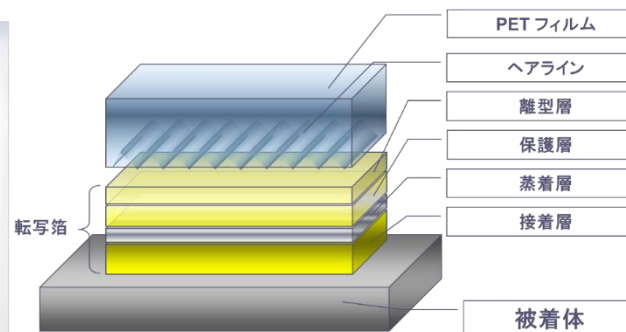
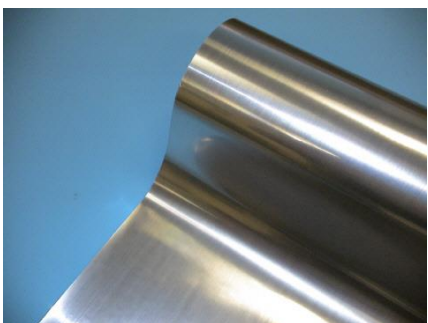

Hairline transfer foil

For building materials

Decoration for home appliances and automobiles

[Pasta processing]

1 This is a window opening process that allows you to see the contents, mainly for food packaging and cosmetics. After full-surface vapor deposition, window opening printing is applied, and chemical etching is used to partially wash off the vapor deposition layer with chemicals. "Processing."

2. The status of the contents can be checked, and the design is excellent due to the gradation, etc.

1 t is a window opening process that allows you to see the contents mainly for food packaging and cosmetics. After full-surface vapor deposition, window opening printing is applied, and chemical etching is used to partially wash off the vapor deposition layer with chemicals. "Processing."

2 The status of the contents can be checked, and the design is excellent due to the gradation, etc.

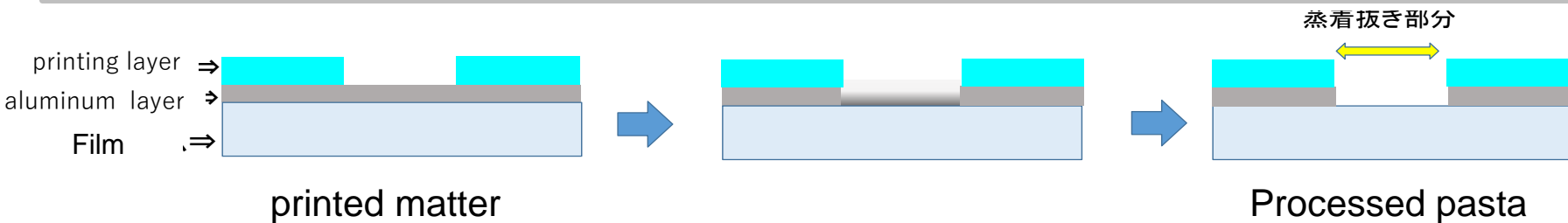

printing layer
aluminum deposition layer
film
Usage example of pasta processing ⇒

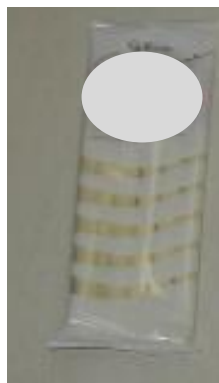

【 Corona discharge treatment 】

- By subjecting various plastic films to corona discharge treatment, the surface energy is increased, Effective in improving the wettability and adhesion of coatings and printing.

[Base film material] PET, PMMA, PC, PP, etc.

[Film thickness] 12 to 350 μm (for PET)

[Width] MAX1360mm

[Winding diameter] MAX560mm ϕ (50 μm : 4000m winding)

<Corona treatment effect: representative example>

PET film: 40 mN/m before treatment \rightarrow 54 mN/m or more after treatment

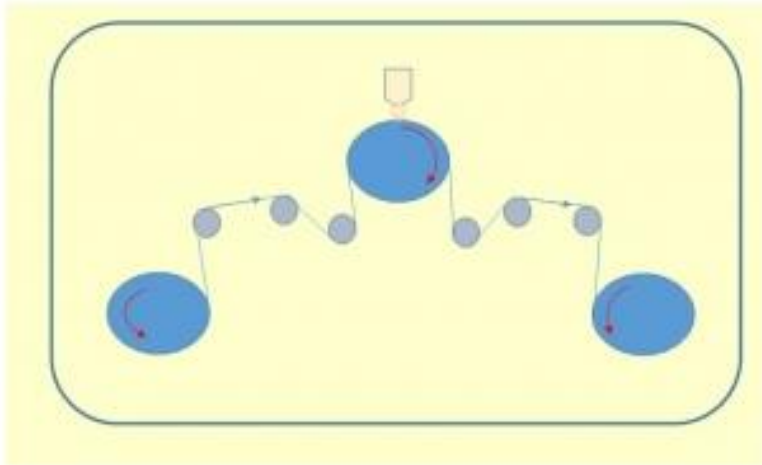

Corona discharge treatment

【 Micro slit processing 】

- With the slit technology cultivated in film capacitors, A micro-slit from a minimum width of 4 mm is possible.
- Materials are PET film and PP film (30 μ m) wound 2,000m with an accuracy of 5.0mm \pm 0.3mm It is possible to

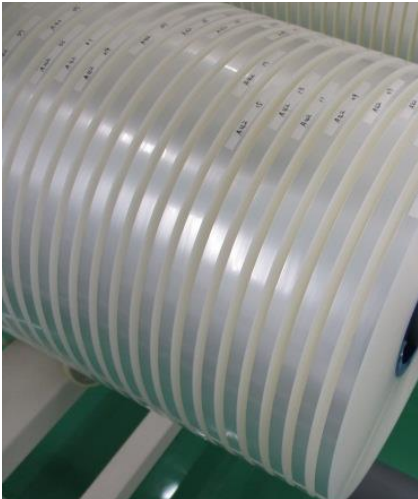

Film slit product

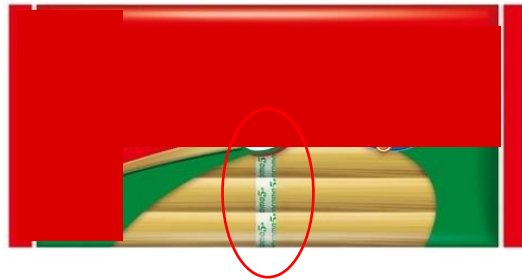

Usage example of slit product: Binding tape for pasta

【 Micro-slit processing of transfer foil 】

- The transfer foil can be slit into narrow width products with a special slitter for transfer foil. We can also handle transfer foil that scatters at the slit.
- The minimum slit width is 12 mm, and up to about 1,000 m for materials with a thickness of 25 μm . "It can be rolled up." 1 inch and 3 inch winding available (paper tube and plastic core)

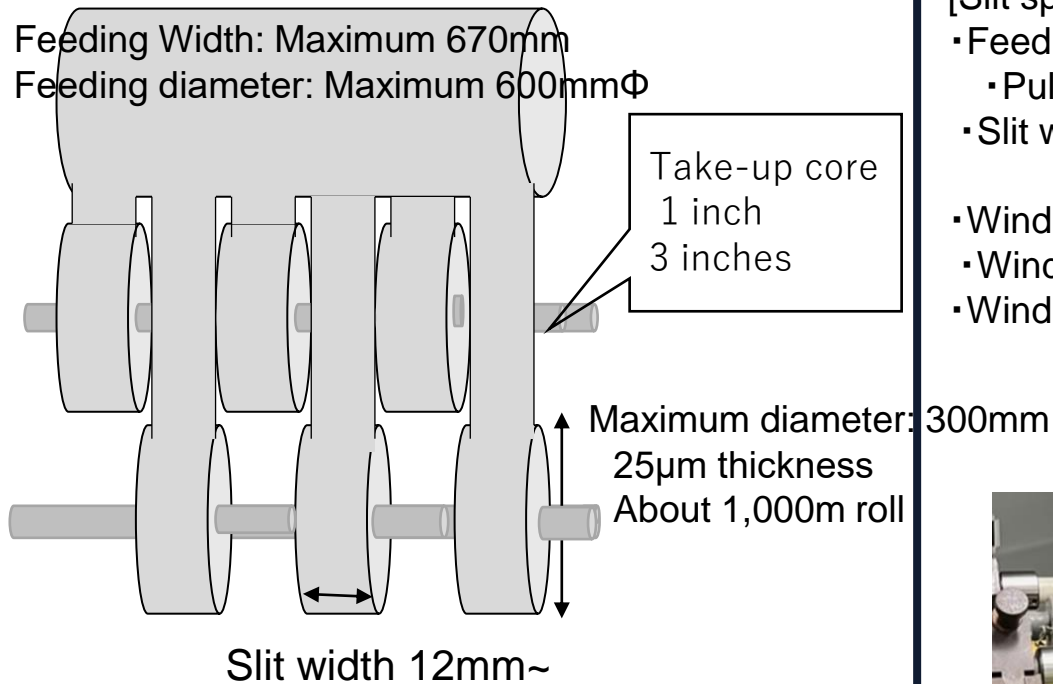

[Slit specifications]

- Feeding width: maximum width of 750 mm
 - Pulling out diameter: Maximum diameter 600mm Φ
- Slit width: Minimum 12 mm Example)
25 μm thickness: about 1,000m roll
- Winding diameter: Maximum 300mm Φ
- Winding core diameter: 1 inch, 3 inch
- Winding core: paper tube, plastic core (ABS, etc.)

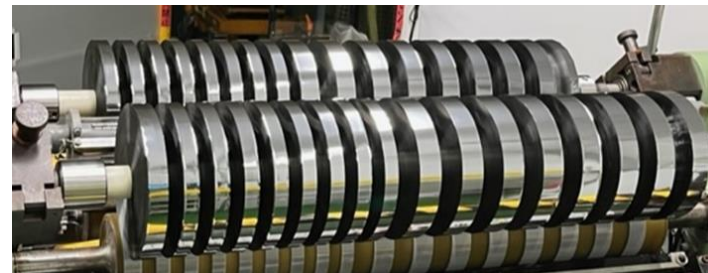

【 Commissioned processing of coating and slit

- Contract coating processing, from colored coating to silicone coating, etc. We accept various coatings.
- The film thickness is 12 to 250 μm , and the maximum film width is 1350 mm.

